

AMiS-50E



Features

- Highly integrated computer and power cart solution for medical applications
- All-In-One Touch Computer or Embedded PC with Intel Core i CPU for high performance for high performance
- 10-hour battery runtime with 420Wh power supply
- 30kg load capacity with motorized height adjustment
- Medical-grade certification compliance
- IPX1 rated for superior infection control
- Keyboard light supports use in dark environments
- 4 x USB and 1x RJ-45 port in VESA mount neck

Specifications

Category	Attribute	AMiS-50E
Base Cart	Footprint	19.7" x 18.5" (500 x 470 mm)
	Casters	125mmx125mm (Anti-Static Medical casters, two locking, two non-locking)
	Height Adjustment Range	34"-45.8"(864-1164mm) Stroke 300mm
	Display Holder	Standard VESA Mount (VESA 75/75; VESA 100/100); Weight capacity: max. 18 kg
	I/O Ports	USB3.0 ports x 4, Gigabit Ethernet Interface (RJ-45) x 1
	Dashboard	Battery power button Computer power button LED for battery capacity indication
	Work surface	18.5" x 19.3" (469.9 x 489.9 mm) Extra Loading Capacity: Up to 66lb/30kg
	Keyboard & Mouse Area	Keyboard size: Up to 380 x 140 x 25mm Keyboard LED light Mouse tray
Accessory extend Used	Neck: Dove Tail Work Surface: Din Rail (Right, Left and Rear)	
Power Module	Battery Type	Lithium-ion
	Battery Capacity	420Wh
	Power Input Voltage	100-240Vac, 50-60Hz, Max 4.5A
	DC Output Voltage	System 1: 19 V _{DC} , Max. 6 A System 2: 12 V _{DC} , Max. 5 A
	Battery Life SPAN	Capacity 80%, 2000cycles or 2 years (Depends on which term come first)
	Battery Charge Time	≤ 3Hr 400Wh
Battery Manager Software	AMiS_Link	Battery capacity indicator Alerts (battery capacity, temperature, warning) Battery Life cycle statistics Report & log file Client Installation Server Installation (Optional) Multi-language support, including Chinese Traditional, Chinese Simple, English, German and Dutch
		Certificate

Computer System Section

Category	Attribute	
All-in-One Computer	CPU	Intel Core i5-7300U 2.6GHz
	Memory	4 GB DDR4 SODIMM
	Storage	2.5" SATA SSD 128GB
	Display	21.5" 1920 x 1080 FHD P-Cap Touch Screen
	WiFi	Intel® Dual Band Wireless-AC 8265
	Speaker	1.5 Watt x 2
	IP Rating	Front Panel: IP65 Entire Computer: IPX1
	Operating System	Win10 IoT

Dimensions

Unit: mm

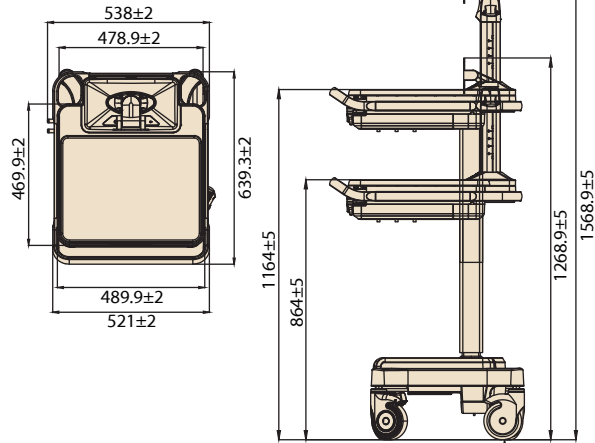

Display Holder I/O



USB 3.0 x 4



Gigabit LAN x1

Control Panel



Battery power

Height adjustment

Computer power

Ordering Information

Power Cart

Part Number	Motor	Computer	Battery
AMIS-50E-1M1K2NE-C	Yes	-	IPS-M420S

All-In-One Touch Computer Cart

Part Number	Motor	Computer	Battery
AMIS-50E-LM1K2N50C	Yes	i5 7300U / 4GB RAM / 128G SSD / Win 10 IoT	IPS-M420S

Peripheral Ordering Information

Power Cord

Part Number	Power Cord Type (Spiral)
1700019822	China
1700019823	US
1700019824-11	EU
1700019825	UK
1700020538-01	Australia
1700022626-01	Brazil

DIN Rail & Dove Tail

For accessory and device integration



DIN Rail

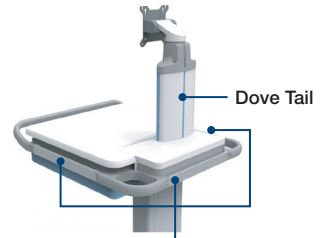

Side Din Rail

Battery

IPS-M420S Li-ion Battery



AMiS_Link

